

MAX



User Manual

Rolling Garage Door Opener



www.tmt-automation.com

Index

Warnings	P2
Kit contents	P3
Specifications	P3
Installation tools	P4
Before installation	P4
Manual release	P4
Installation	P5
Control panel	P7
Transmitter	P8
System learning	P9
LED indication	P11
Parameters	P12
Photocell	p16
Photocell mode	p18





Warnings

WARNING:

Please read this instruction manual carefully before the installation.

This manual is exclusively for qualified installation personnel.

TMT automation Inc. is not responsible for improper installation and failure to comply with local electrical and building regulations.

Keep all the components of MAX rolling garage door opener and this manual for further consultation.

*****Do make sure the door has been fully opened and stopped before any person or vehicle to enter or exit the door area.**

TMT Automation Inc. is not responsible for any damage or injury to person or vehicle that enter or exit without door been stopped at fully open position.

Installers must inform this warning to users in person after the motor installation.***

- In this manual, please pay extra attention to the contents marked by the symbol. 
- Be aware of the hazards that may exist in the procedures of installation and operation of the rolling garage door opener. Besides, the installation must be carried out in conformity with local standards and regulations.
- If the system is correctly installed and used following all the standards and regulations, it will ensure a high degree of safety.
- Make sure that the door works properly before installing. The doors are appropriate for the application.
- Do not let children operate or play with the rolling garage door opener.
- Do not cross the path of the rolling garage door opener system when operating.
- Please keep all the control devices and any other pulse generator away from children to avoid the system being activated accidentally.
- Do not make any modifications to any components except that it is mentioned in this manual.
- Do not try to manually open or close the doors before you release the rolling garage door opener.
- If there is a failure that cannot be solved and is not mentioned in this manual, please contact qualified installation personnel.
- Do not use the rolling garage door opener system before all the procedures and instructions have been carried out and thoroughly read.
- Install warning signs (if necessary) on the both sides of the door to warn the people in the area of potential hazards.
- If the supply cord is damaged, it must be replaced by the manufacturer, its service agent or similarly qualified persons in order to avoid hazard.
- This appliance is not intended for use by children or persons with reduced physical, sensory or mental capabilities, or lack of experience and knowledge, unless they have been given supervision or instruction by a person responsible for their safety.
- **WARNING:** Important safety instructions. It is important for the safety of persons to follow all instructions. Save these instructions.
- Watch the moving door and keep people away until the door is completely opened or closed.
- Take care when operating the manual release since an open door may fall rapidly due to weak or broken springs, or being out of balance.
- Frequently examine the installation, in particular check cables, springs and mountings for signs of wear, damage or imbalance. Do not use if repair or adjustment is needed since a fault in the installation or an incorrectly balanced door may cause injury.
- Each month check that the drive reverses when the door contacts a 40 mm high object placed on the floor. Adjust if necessary and recheck since an incorrect adjustment may present a hazard.
- Disconnect the supply when cleaning or carrying out other maintenance.
- **WARNING:** Important safety instructions. Follow all instructions since incorrect installation can lead to severe injury.
- For drives supplied without a door, the installation instructions shall indicate the type, size and mass of doors for which the drive is intended to be used.
- Before installing the drive, remove all unnecessary ropes or chains and disable any equipment, such as locks, not needed for powered operation.
- Before installing the drive, check that the door is in good mechanical condition, correctly balanced and opens and closes properly.
- Install any fixed control at a height of at least 1,5 m and within sight of the door but away from moving parts.
- Permanently fix the label concerning the manual release adjacent to its actuating member.
- The drive must not be used with a door incorporating a wicket door.
- After installation, ensure that parts of the door do not extend over public footpaths or roads.
- **WARNING:** Keep children away when the door is moving.
- **WARNING:** Risk of entrapment – Regularly check and, if necessary, adjust to ensure that, when the door contacts a 40 mm high object placed on the floor, the door reverses or the object can be freed.
- Drives shall be supplied with a label suitable for permanent fixing that describes how to use the manual release.

Kit contents

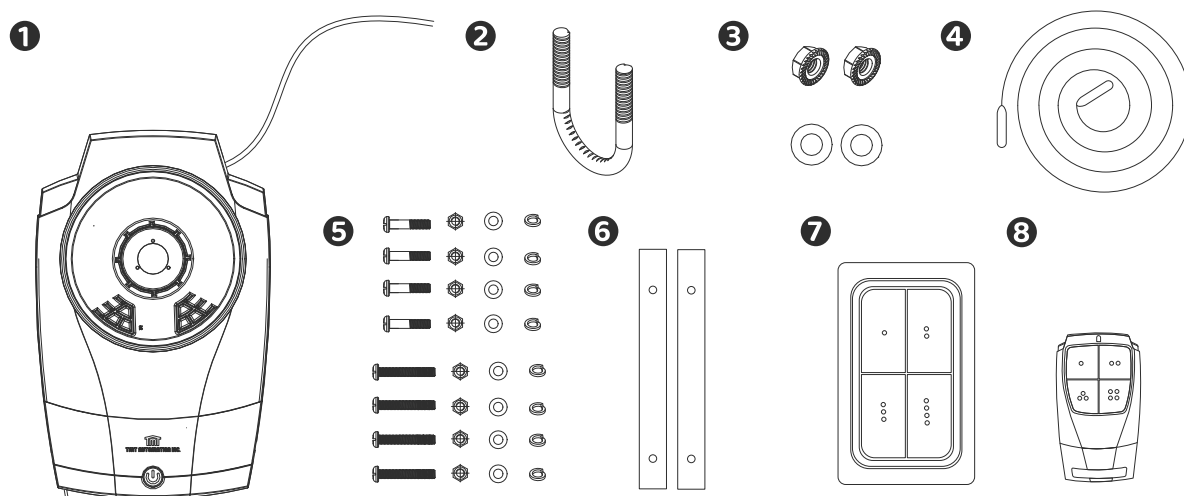

- 1** MAX **2** Bracket **3** Fasten board **4** Release device **5** Installation kit
6 Weight bar **7** Push button **8** Remote

Specification

Model	MAX
Power	DC 24V
Temperature	0°C-50°C
Watt	120W
Normal force	200N
Max Pull Force	650N
Door axle	35mm
Max Drum Rotations	4 (approx. 3000mm)
Max Door Area	6M x 3M=18M ²
Noise test	<60db

Model	P801U
Power	220V, 50-60HZ
Frequency	433MHZ
Memory Registers	200
Temperature	0°C-50°C

Installation tools

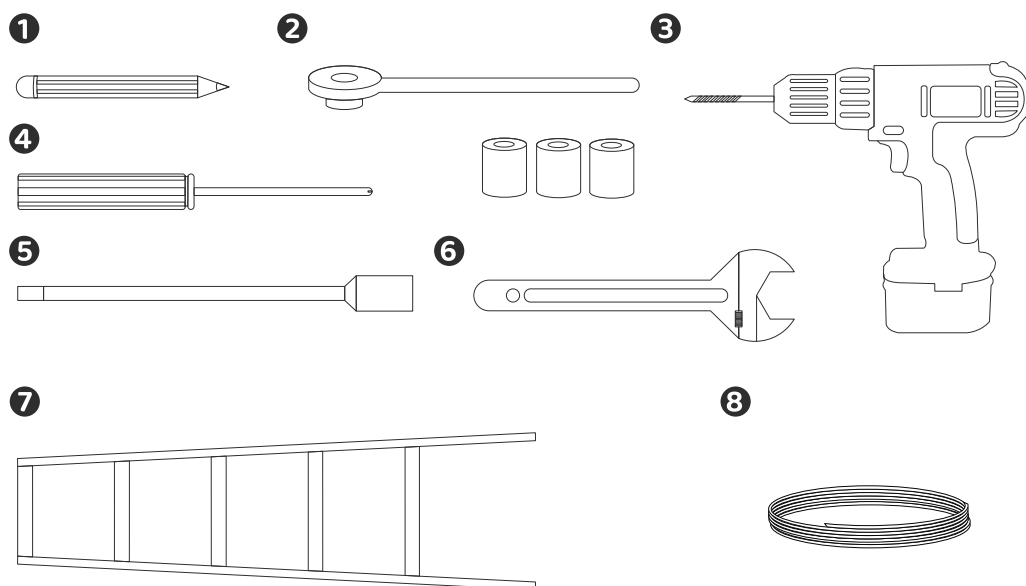

- 1** Pen / Pencil **2** Socket wrench **3** Electric screwdriver **4** Screwdriver
5 Long socket **6** Active wrench **7** Ladder **8** Rope **9** Door stand (not shown)

Before installation

Please check the door status before installation.

- a. Make sure the door runs smoothly.
- b. Make sure the door is well maintained.
- c. Please consult qualified installation.

- A. Depth of motor turntable.
- B. Depth of the motor.
- C. Distance from roller door turntable to wall.
- D. Width of the stand.

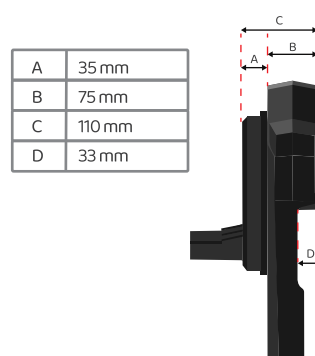

A	35 mm
B	75 mm
C	110 mm
D	33 mm

Manual release

- a. Please pull the red release wire till the gear system is disconnected.
- b. Pull the opposite wire till the gear system is connected.



Installation

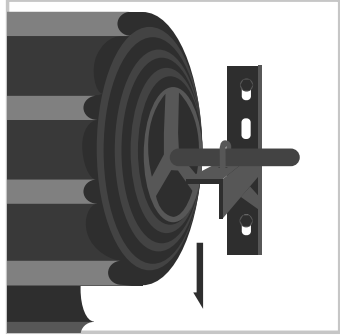

- 1 Check the door must travel smoothly and be easy to operate by hand.

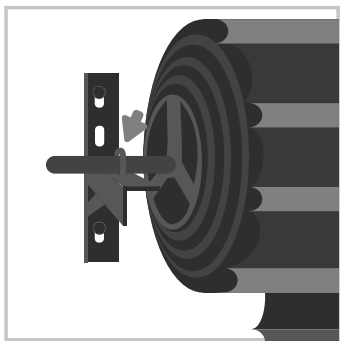

- 3 Ensure the door axle U-Bolt and door mounting bracket on non installation side are securely fastened.

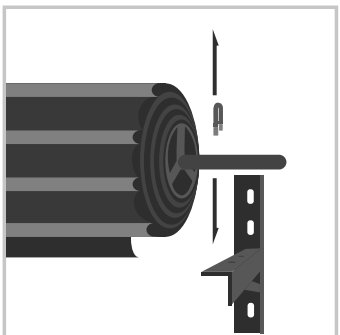

- 5 Remove the right hand axle U-Bolt and door mounting bracket from the wall.

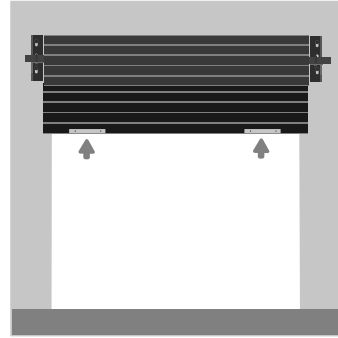

- 2 Put the weight bars equally apart on the bottom rail of the door and fasten them with the small screws and nuts in (6) Installation kit.

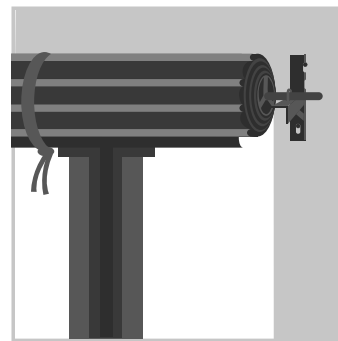

- 4 Secure a rope over the door and not at the bottom, support the door with a door stand or similar device to safely support the door.

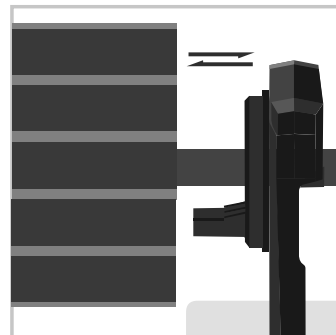

- 6 Slide the opener over the door axle and engage the drive legs into the door drum wheel, either side of a spoke.

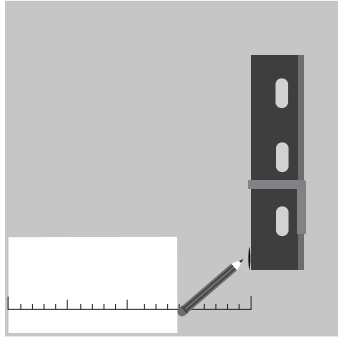

- 7** Refit the door mounting bracket to the wall.
If the door bracket needs to be relocated due to opener width.

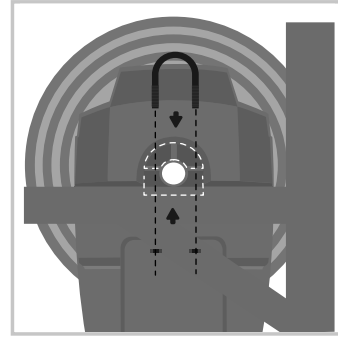

- 8** Clamp the opener on the door axle and door bracket in the marked position using the clamp assembly supplied.

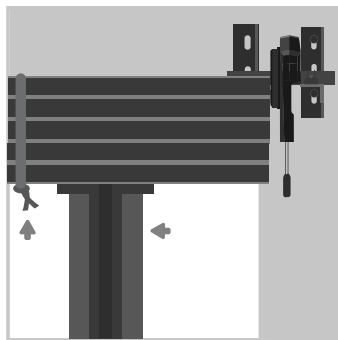

- 9** Remove all ropes and the support stand.

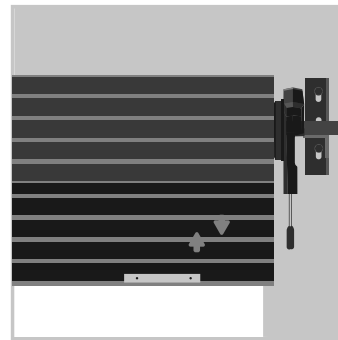

- 10** Check the operation of the door in manual mode by raising and lowering by hand.
It should operate smoothly without sticking or binding.

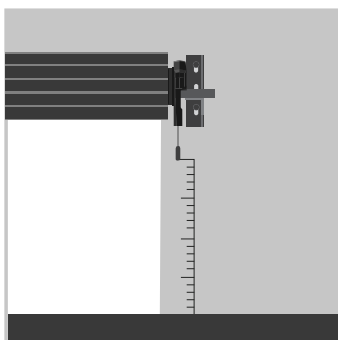

- 11** The disengage handle should already be attached less than 1.8m above the floor.

Control panel

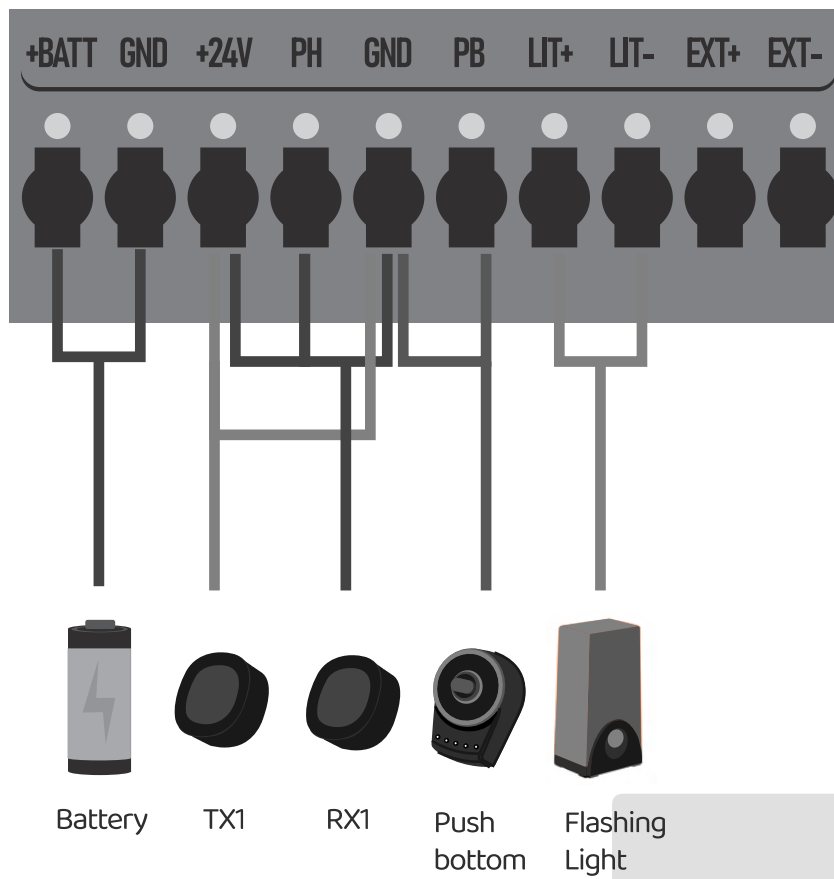

Battery

TX1

RX1

Push bottom

Flashing Light



Transmitter

*****If you have more than 1 remote to memory,
follow the above procedure within the CS period.*****

Transmitter Memorizing

Press "**RF Learn**" button for **3 seconds**, and the display will show "**CS**"; then press the transmitter **button A** within 10 seconds; the "**CS**" will blink **three times** and show "**CS**". After 10 seconds without any movement, "**CS**" will be **off**. The transmitter learning is completed.

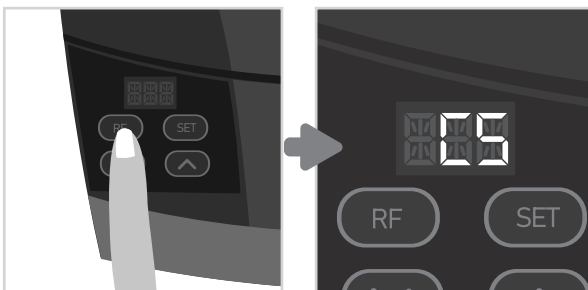

Erasing Transmitter Memory

Press and hold "**RF Learn**" button for **10 seconds**, the display will show "**CS**". When "**CC**" show up, the memory is cleared.



Memorizing by memorized transmitter

- Press and hold **button A and B** for **5 seconds**, LED light and external flash light will blink.
- Within 10 seconds, press any button of the **un-memorized transmitter 2 seconds**.
- The transmitter will be memorized after LED light and external flash light are off.

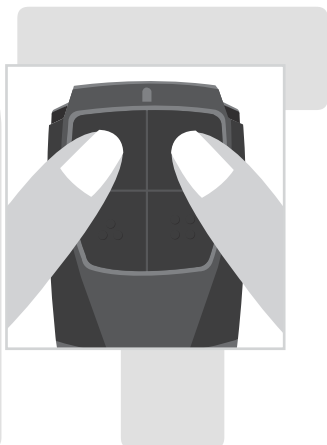

System learning

Before start the system learning procedure, do make sure the motor installation direction, default is F1-1 on the right.

System Learning

a. LED display show "N-L" when didn't system learning yet.



b. Press "RF" & "SET" button together for **3 seconds** and the LED display show "OL" to set the OPEN limit by using the "UP" or 'DOWN' button.

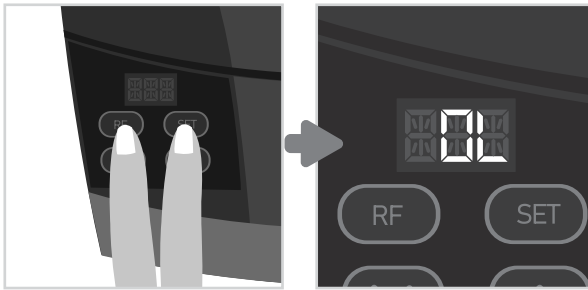

c. Press "UP" button to open the door to the desire open position, and press "SET" button to confirm the OPEN limit.

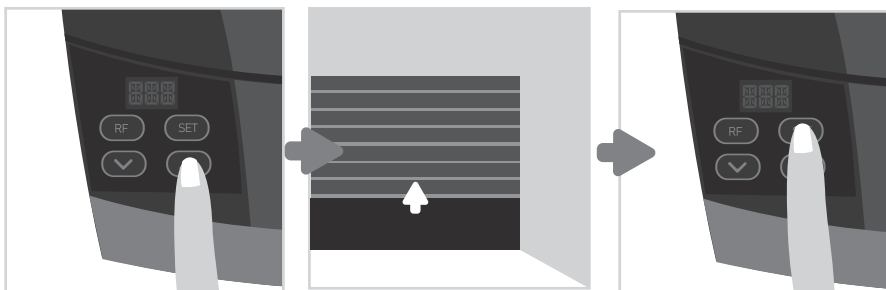

d. LED display show **"CL"** to set CLOSE limit, press **"DOWN"** to close the door to the desire close position, and press **"SET"** button to confirm the CLOSE limit.

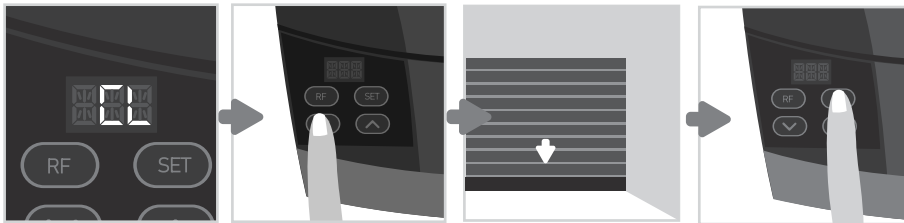

e. LED display show **"GE"** to do the automatic testing run, press **"SET"** to start, and the door will open and close automatically.

*****DO NOT** interrupt the automatic testing run procedure by press any button or remote, LED display show **"RUN"** which indicate the system learning has been completed.*******

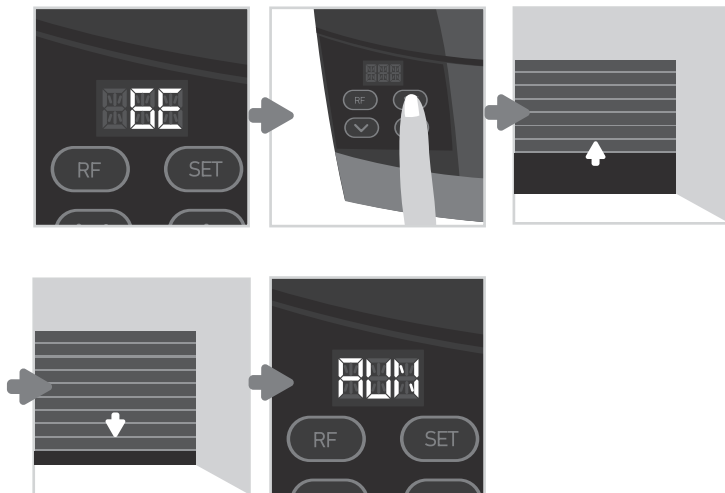

NOTICE

Please follow bellow instructions, while encountering power outage and power restored.

- Please press the remote button and the system will calibrate automatically.
The system will go through the grating in order to locate itself and continue opening or closing.
- While starting the system by pressing the remote button, please make sure the system runs for a sufficient period of time.
The system will go through the grating in order to memorize the whole travel and to continue opening or closing.
- If the system locates around the grating open position, the system will close while press the remote button.
If the system locates around the grating close position, the system will open while press the remote button.
If the system locates at the grating, the system will follow the step by step remote logic (Open/Stop/Close/Stop).

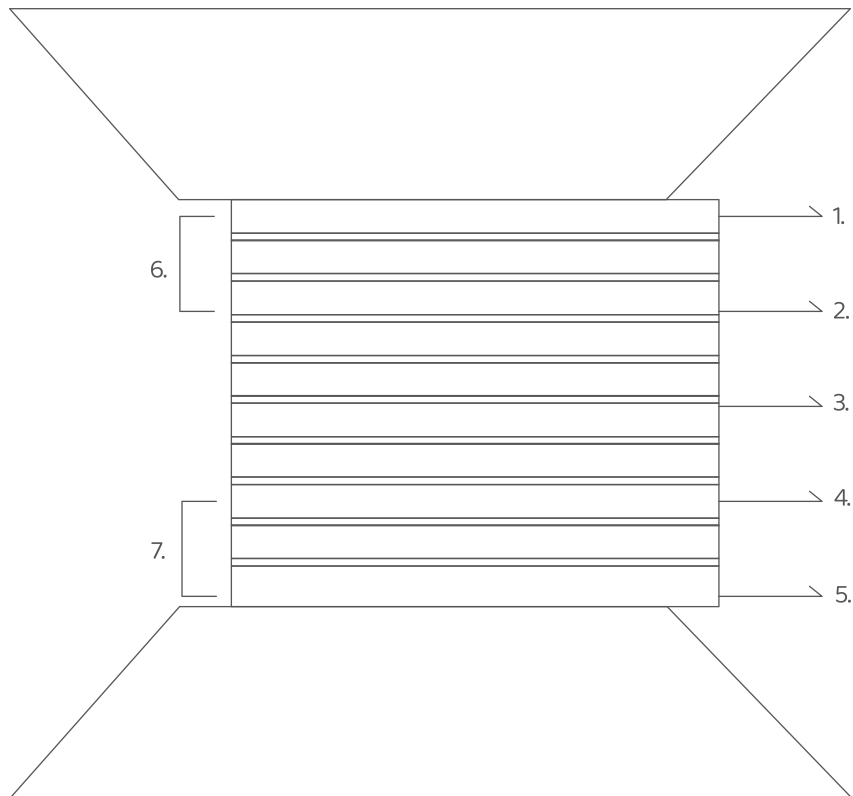

1. Open position
2. Grating 1
3. Grating 2
4. Grating 3
5. Close position
6. If the system locates around the grating open position, the system will close while press the remote button.
7. If the system locates around the grating close position, the system will open while press the remote button.

LED indication

LED display	Indication
OL	Set open limit
CL	Set close limit
GE	System leaning auto run
N-L	Default setting
RUN	System learning completed

Parameters

Parameter setting

Step 1: Press **"SET"** for 3 seconds, the display will show the function code.

Step 2: Choosing the setting by **"UP"** and **"DOWN"**, after having chosen the indicated item, press **"SET"** and enter the setting of this function.

The second digit will be shown on the right of the display, indicating the related function (please refer below chart for details).

Using **"UP"** and **"DOWN"** to choose the setting function and press **"SET"** key to save.

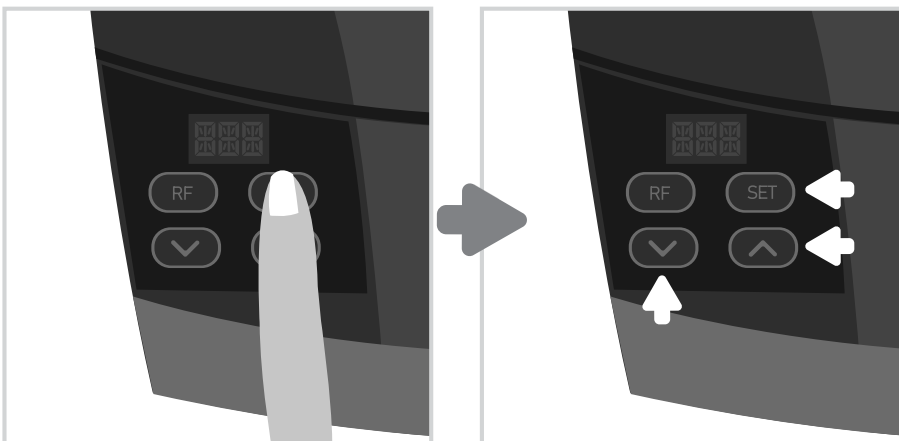

*****Before start the system learning procedure, do make sure the motor installation direction, default is F1-1 on the right.*****

LED display	Definition	Parameter	Table	Description
F1	Direction	F1-1		Default setting is F1-1.
		F1-2		
F2	A button	F2-0	No function	Default setting is F2-1 F2-5 function is controlled by FK
		F2-1	Open/Stop/Close/Stop	
		F2-2	LED light	
		F2-3	EXT button	
		F2-4	Condominium mode (Open only)	
		F2-5	Ventilation mode	
F3	B button	F3-0	No function	Default setting is F3-2 F3-5 function is controlled by FK
		F3-1	Open/Stop/Close/Stop	
		F3-2	LED light	
		F3-3	EXT button	
		F3-4	Condominium mode (Open only)	
		F3-5	Ventilation mode	

LED display	Definition	Parameter	Table	Description
F4	C button	F4-0	No function	Default setting is F4-0 F4-5 function is controlled by FK
		F4-1	Open/Stop/Close/Stop	
		F4-2	LED light	
		F4-3	EXT button	
		F4-4	Condominium mode (Open only)	
		F4-5	Ventilation mode	
F5	D button	F5-0	No function	Default setting is F5-0 F5-5 function is controlled by FK
		F5-1	Open/Stop/Close/Stop	
		F5-2	LED light	
		F5-3	EXT button	
		F5-4	Condominium mode (Open only)	
		F5-5	Ventilation mode	
F6	Photocell mode	F6-0	OFF	Default setting is F6-0 Please refer to Page13 "Photocell mode"
		F6-1	Mode 1	
		F6-2	Mode 2	
		F6-3	Mode 3	
		F6-4	Mode 4	
F7	Alarm	F7-0	Function OFF	Default setting is F7-0 (Door open for 30 minutes and the buzzer rings for 1 minute until the motor reach the close limit.)
		F7-1	Function ON	
F8	Auto-closing	F8-0	OFF	Default setting is F8-0
		F8-1	Close after 15 seconds	
		F8-2	Close after 30 seconds	
		F8-3	Close after 45 seconds	
		F8-4	Close after 60 seconds	
		F8-5	Close after 90 seconds	
		F8-6	Close after 120 seconds	
		F8-7	Close after 150 seconds	
		F8-8	Close after 200 seconds	
F9	LED light	F9-0	OFF	Default setting is F9-3
		F9-1	Light ON for 30 seconds	
		F9-2	Light ON for 1 minute	
		F9-3	Light ON for 2 minutes	
		F9-4	Light ON for 3 minutes	

LED display	Definition	Parameter	Table	Description
FA	Over-current reaction	FA-1	Stop when over-current while opening and closing. The buzzer rings for 5 seconds.	Default setting is FA-2 The system will close auto-closing when encountering over-current until the system reach the limit.
		FA-2	Stop when over-current while opening. Buzzer rings for 5s and stop. Stop and reverse to open when over-current while closing. Buzzer rings for 5s and stop.	
FC	Over-current tolerance value	FC-1	Increase 0.2A against learning current	Default setting is FC-5
		FC-2	Increase 0.4A against learning current	
		FC-3	Increase 0.5A against learning current	
		FC-4	Increase 0.6A against learning current	
		FC-5	Increase 0.8A against learning current	
		FC-6	Increase 1.0A against learning current	
		FC-7	Increase 1.2A against learning current	
		FC-8	Increase 1.4A against learning current	
		FC-9	Increase 1.6A against learning current	
		FC-A	Increase 1.8A against learning current	
FE	Over-current value for system learning (open)	FE-1	2A	Default setting is FE-6
		FE-2	3A	
		FE-3	4A	
		FE-4	5A	
		FE-5	6A	
		FE-6	7A	
		FE-7	8A	
FF	Over-current value for system learning (close)	FF-1	2A	Default setting is FF-6
		FF-2	3A	
		FF-3	4A	
		FF-4	5A	
		FF-5	6A	
		FF-6	7A	
		FF-7	8A	
FG	Opening speed	FG-1	100%	Default setting is FG-1
		FG-2	90%	
		FG-3	80%	
		FG-4	70%	
		FG-5	60%	
		FG-6	50%	
FH	Closing speed	FH-1	100%	Default setting is FH-3
		FH-2	90%	
		FH-3	80%	
		FH-4	70%	
		FH-5	60%	
		FH-6	50%	

LED display	Definition	Parameter	Table	Description
FI	Soft start	FI-1	1.0 Second Ramp	Default setting is FI-4
		FI-2	1.5 Second Ramp	
		FI-3	2.0 Second Ramp	
		FI-4	2.5 Second Ramp	
		FI-5	3.0 Second Ramp	
		FI-6	3.5 Second Ramp	
		FI-7	4.0 Second Ramp	
		FI-8	4.5 Second Ramp	
		FI-9	5.0 Second Ramp	
FJ	Soft stop	FJ-1	1.0 Second Ramp	Default setting is FJ-4
		FJ-2	1.5 Second Ramp	
		FJ-3	2.0 Second Ramp	
		FJ-4	2.5 Second Ramp	
		FJ-5	3.0 Second Ramp	
		FJ-6	3.5 Second Ramp	
		FJ-7	4.0 Second Ramp	
		FJ-8	4.5 Second Ramp	
		FJ-9	5.0 Second Ramp	
FK	Ventilation mode	FK-0	OFF	Default setting is FK-0
		FK-1	10% of the travel	
		FK-2	20% of the travel	
		FK-3	30% of the travel	
		FK-4	40% of the travel	
		FK-5	50% of the travel	
FL	Flashing light	FL-0	OFF	Default setting is FL-0
		FL-1	ON	
FM	24V terminal	FM-1	Constantly 24V output	Default setting is FM-1
		FM-2	24V output but no output while at the close position	
FN	PB terminal	FN-1	Open/Stop/Close/Stop	Default setting is FN-1
		FN-2	Open	

LED display	Definition	Parameter	Table	Description
FP	Return to the default setting	FP-1	Return to the default setting but keep the remote memory and system learning	Default setting is FP-1
		FP-2	Return to the default setting	
FR	Motor operation record	001	<100 times	
		002	101-200 times	
		003	201-300 times	
		004	301-400 times	
		005	401-500 times	
		006	501-600 times	
		007	601-700 times	
		008	701-800 times	
		009	801-900 times	
		010	901-1000 times	
		110	10999-11000 times	
		200	>19999 times	

Photocell

The safety photocells are security devices for control automatic gates. Consist of one transmitter and one receiver based in waterproof covers; it is triggered while breaking the path of the beams.

Specification

Derection method	Through beam
Sensing range	15m
Input voltage	AC/DC 12~24
Response time	100MS
Emitting element	Infrared LED/ Wave Length : 940nm
Operation indicator	RX : Red LED On (beam broken) / Off (beam aligned) TX : Red LED On
Dimentions	63x63x30mm
Output method	Relay output
Current consumption max	Beam aligned : RX<25ma\TX<30ma Beam broken : RX <10ma\TX <30ma
Water proof	IP44

Photocell connection

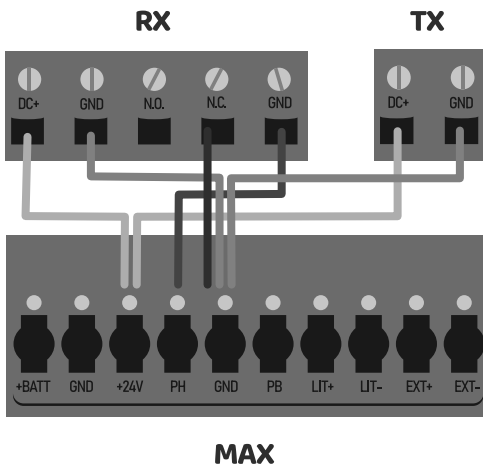
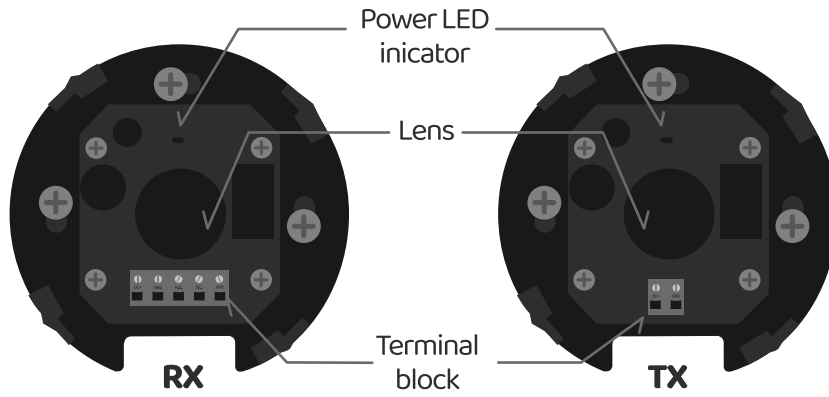

TX. Connect the DC+ of the TX to the +24V.
Connect GND of the TX to GND.

RX. Connect the DC+ of the RX to the +24V.
Connect the GND of the RX to GND.
Connect the N.C. of the RX to GND.
Connect the GND of the RX to PH.

INSTALLATION:

1. Open the cover and connect wires.
2. Mounted the receiver and transmitter on the proper position.
3. Ensure there are no obstacles between receiver and transmitter.
4. For optimal efficiency, the receiver and transmitter should be properly aligned.
5. Power-up the photocells and make sure the LED light on receiver and transmitter are ON.

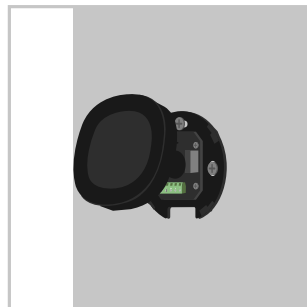
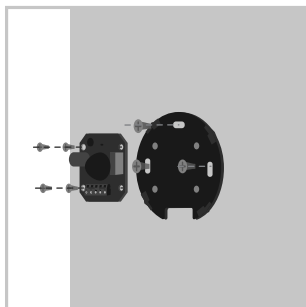
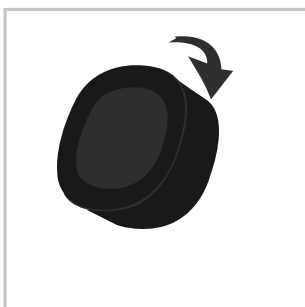

Photocell mode

F6-1

Gate status	Action when photocell is triggered
Fully closed	No effect
Fully open	Open and close not allowed and waiting for the next commend. Reload auto-closing time when the obstacle is removed.
Stop in the middle	Open and close not allowed and waiting for the next commend. Reload auto-closing time when the obstacle is removed.
Closing	The system stops and waiting for the next commend. The buzzer rings for 5 seconds.
Opening	The system stops and waiting for the next commend. The buzzer rings for 5 seconds.

F6-2

Gate status	Action when photocell is triggered
Fully closed	No effect
Fully open	Open and Close not allowed and waiting for the next commend. Reload auto-closing time when the obstacle is removed.
Stop in the middle	Close not allowed and waiting for the next commend. Reload auto-closing time when the obstacle is removed.
Closing	The system stops and waiting for the next commend. The buzzer rings for 5 seconds.
Opening	No effect

F6-3

Gate status	Action when photocell is triggered
Fully closed	No effect
Fully open	Open and Close not allowed and waiting for the next commend. Reload auto-closing time when the obstacle is removed.
Stop in the middle	Close not allowed and waiting for the next commend. Reload auto-closing time when the obstacle is removed.
Closing	The system reverse to open and waiting for the next commend. The buzzer rings for 5 seconds.
Opening	No effect

F6-4

Gate status	Action when photocell is triggered
Fully closed	No effect
Fully open	Open and Close not allowed and waiting for the next command. Reload auto-closing time when the obstacle is removed.
Stop in the middle	Close not allowed and waiting for the next command. Reload auto-closing time when the obstacle is removed.
Closing	The system reverse to open for 1 second and waiting for the next command. The buzzer rings for 5 seconds.
Opening	No effect



nt

TMT AUTOMATION INC

TMT AUTOMATION INC

tmt

nt

TMT AUTOMATION INC

TMT AUTOMATION INC